

	<p>MINIMESS® Reihe 1620 - Testpunkte und Zubehör MINIMESS® series 1620 - test points and equipment</p>	
	<p>Der MINIMESS® Testpunkt ist ein mechanisch entsperres Rückschlagventil und dient als Systemzugang für Analyseaufgaben und Untersuchungen in fluiden Kreisläufen.</p> <p>Der Testpunkt ist fester Bestandteil der Mess- und Prüftechnik und erlaubt, schnell und ohne Anlagenstillstand, Drücke und Temperaturen zu messen. Das Kuppeln der Anschlussseite kann im Druck beaufschlagten Zustand stattfinden.</p>	<p><i>The MINIMESS® test point is a mechanically unlockable non- return valve that is used to access the hydraulic system for diagnostics in fluid circuits.</i></p> <p><i>The test point is a component part of the measurement and inspection technology and allows fast pressure and temperature measurement without system downtime. Coupling the connection side can be done under system pressure.</i></p>

<p>Verwendungszweck Designated use</p>	<p>Der MINIMESS® Testpunkt bildet den Systemzugang für Analyseaufgaben, Probeentnahmen, Befüllung oder Entlüftung in Kreisläufen mit flüssigen Medien der Gruppe 2 gemäß Klassifizierung der Druckgeräterichtlinie 2014/68/EU (ungefährliche Fluide).</p> <p>Weitere Einsatzbereiche sind überall dort zu finden, wo die Medienverträglichkeit und der Temperaturbereich den Einsatz der MINIMESS® Testpunkte zulassen.</p>	<p><i>The MINIMESS® test point allows access to the system for diagnostics, sample taking, filling and ventilation in circuits working with liquids of group 2 according to the classifications of the Pressure Equipment Directive 2014/68/EU (non- dangerous fluids).</i></p> <p><i>Further applications are possible, if the media and the temperature range is in accordance with this specification.</i></p>
--	---	---

<p>Medienverträglichkeit Media compatibility</p>	<ul style="list-style-type: none"> • Ohne Einschränkung geeignet für HL, HLP, HVLP nach DIN 51524 • Nur eingeschränkt beständig gegenüber schwerentflammbaren oder umweltverträgliche Hydraulikölen: HEES, HEPR, HEPG; HFDM, HFDR, HFC nach ISO 12922 und ISO15380¹ • Die Beständigkeit der O-Ringe sowie der Oberfläche sind bei abweichenden Medien im Einzelfall abzustimmen 	<ul style="list-style-type: none"> • <i>Suitable without limitations for HL, HLP, HVLP according to DIN 51524.</i> • <i>Limited resistance to low flammable fluids or environmentally friendly hydraulic oils: HEES, HEPR, HEPG; HFDM, HFDR, HFC according to ISO 12922 and ISO15380¹</i> • <i>The chemical resistance of the O-ring and the material surface with other media has to be checked case by case.</i>
--	---	--

¹ Bei Gebrauch von schwerentflammbaren oder umweltverträglichen Hydraulikölen kann es zu Einschränkungen der technischen Daten kommen (Temperatur, Druckbereich, Lebensdauer, etc.).

When using flame-resistant or environmentally compatible hydraulic fluids, restrictions with regard to the technical data may be applicable (temperature, pressure range, life time, etc.)

<p>Qualifikationskriterien <i>Qualification criteria</i></p>	<p>MINIMESS® Testpunkte, sowie MINIMESS® Zubehör werden nach einschlägig bekannten Normen getestet und qualifiziert. Für nicht normierte Eigenschaften werden in Anlehnung an Normen verwandter Produkte eigene Testkriterien definiert. Nur insoweit werden Eigenschaften zugesichert.</p> <p>Die Qualifikation erfolgt an Baumustern des genannten Artikels oder an Teilen, die in Bezug auf die zu untersuchenden Eigenschaften identisch sind.</p>	<p><i>MINIMESS® test points and MINIMESS® equipment are tested and qualified in accordance to relevant engineer standards. For properties which are not defined in any norm for the given product, test criteria are based on norms for similar products. Any liability is limited accordingly.</i></p> <p><i>The product qualification was carried out on samples of the article or on parts with identical properties with respect to the criteria under investigation.</i></p>
<p>Druckanstiegsrate <i>Rate of pressure rise</i></p>	<p>Die maximal zulässige Druckanstiegsrate beträgt das 240-fache des maximalen Betriebsdrucks pro Sekunde.</p>	<p><i>The maximum allowable pressure rise rate is 240 times the maximum operating pressure per second.</i></p>
<p>Korrosionsbeständigkeit <i>Corrosion resistance</i></p>	<p>MINIMESS® Testpunkte und MINIMESS® Zubehör aus Automatenstahl werden mit einer Zink-Nickel-Beschichtung gegen Korrosion geschützt. Die Korrosionsbeständigkeit wurde mittels 720h Salzsprühnebeltest nach DIN EN ISO 9227 nachgewiesen.</p>	<p><i>MINIMESS® test points and MINIMESS® equipment made of free-cutting steel are protected against corrosion with a zinc-nickel coating. The corrosion resistance was verified by 720h salt spray test according to DIN EN ISO 9227.</i></p>
<p>Allgemeine Hinweise <i>General information</i></p>	<p>Die Produkte dürfen nur ihrer Bestimmung gemäß verwendet werden. Die Prüfung der Eignung für den vom Auftraggeber vorgesehenen Verwendungszweck bzw. den Einsatz unter Gebrauchsbedingungen, obliegt dem Auftraggeber; hierfür übernimmt die Hydrotechnik GmbH keine Gewährleistung.</p> <p>Änderungen an Produkten und Dokumentationen im Sinne des technischen Fortschritts und der stetigen Verbesserung sind vorbehalten und können jederzeit ohne vorherige Mitteilung eintreten. Die dann gültigen Spezifikationen können von den Angaben in dieser Revision des technischen Datenblatts abweichen.</p> <p>Druckfehler sind vorbehalten.</p> <p>Im Zweifelsfall gilt die deutsche Sprachversion.</p>	<p><i>All of the devices and components listed may be used for their intended purpose only. It remains to the customer's responsibility to qualify whether the device is suitable for the customer's intended purpose and the intended conditions of use or not; we do not assume any liability in this respect.</i></p> <p><i>Changes of products and documentation in the sense of technical progress and continuous improvement may occur at any time without prior notification. Hence specifications may than differ from those given in this revision of the technical data sheet.</i></p> <p><i>There is no liability for possible misprints.</i></p> <p><i>The German language version is valid in any case of doubt.</i></p>



<p>EU-Richtlinien <i>EU directives</i></p>		
<p>PED Druckgeräterichtlinie / Pressure equipment directive</p>	<p>Die Produkte sind gemäß der Druckgeräterichtlinie 2014/68/EU (Kapitel 4) in Übereinstimmung mit geltender guter deutscher Ingenieurpraxis ausgelegt und hergestellt worden. Damit ist die Produktsicherheit gewährleistet. Diese Produkte sollen die CE-Kennzeichnung unbeschadet der sonstigen Harmonisierungsrechtvorschriften der Union, die für das Anbringen dieser Kennzeichnung gelten, nicht tragen.</p>	<p><i>The products are designed and produced in reference to the Pressure Equipment Directive 2014/68/EU (chapter 4), in accordance with German engineering practice. Hence, the product safety is guaranteed. The products shall not have a CE label as far as the Pressure Equipment Directive is concerned.</i></p>
<p>RoHS Beschränkung gefährlicher Stoffe/ Restriction of Hazardous Substances Directive</p>	<p>Diese Produkte unterliegen nicht der Richtlinien 2011/65/EU. Die Materialzusammensetzung ist so gewählt, dass die Produkte in Geräte der Kategorie 9 „Überwachungs- und Kontrollinstrumente in der Industrie“ eingesetzt werden können (Ausnahme 6a).</p>	<p><i>These products are not in the scope of directive 2011/65/EU.</i> <i>The material composition is selected in such a way that the products can be used in devices of category 9 "monitoring and control instruments in industry" (exception 6a).</i></p>
<p>California Proposition 65</p>	<p>Falls dieses Produkt im US-Bundesstaat Kalifornien in Verkehr gebracht wird, muss es mit einer der folgenden Warnungen versehen werden. <i>If this product is placed on the market in the US state of California, one of the following warnings must be given on the product.</i></p>	<p><i>WARNING: This product can expose you to lead, which is known to the State of California to cause cancer and birth defects or other reproductive harm. For more information go to www.P65Warnings.ca.gov.</i> <i>WARNING: This product can expose you to nickel, which is known to the State of California to cause cancer. For more information go to www.P65Warnings.ca.gov.</i></p>

<p>REACH-Regulation (EU)</p>	<p>Die Produkte stehen in Übereinstimmung mit der REACH-Verordnung (EG) No.1907/2006 in seinem bei Inverkehrbringen der Wahre aktuellen Änderungsstand. Es sind keine nach Anhang XVII bezogen auf den angegebenen Verwendungszweck unserer Produkte verbotenen Stoffe enthalten.</p> <p>Gemäß Artikel 33 der REACH-Verordnung informieren wir Sie hiermit, dass von uns gelieferte Produkte aus Automatenstahl bis zu 0,35% Massenanteile Blei und Produkte aus Messing bis zu 3,5% Massenanteile Blei enthalten können.</p> <p>Außer diesem beinhalten unsere Produkte keine weiteren Stoffe der zum Zeitpunkt des Inverkehrbringens gültigen REACH-Kandidatenliste (SVHC).</p> <p>Die SCIP-Nr. der betroffenen Produkte fragen Sie bitte an bei vertrieb@hydrotechnik.com.</p> <p>Diese können Sie für Ihre vereinfachte SCIP-Meldung (SSN) bei der ECHA verwenden.</p>	<p><i>The products are in accordance with the REACH Regulation (EC) No.1907/2006 in the version valid when placed on the market. It does not contain any substances that are prohibited according to Annex XVII in relation to the intended use of our products. In accordance with Article 33 of the REACH regulation, we hereby inform you that the free-cutting steel products we supply may contain up to 0.35% lead by mass and brass products may contain up to 3.5% lead by mass. Apart from this, our products do not contain any other substances on the REACH candidate list (SVHC) that was valid at the time they were placed on the market.</i></p> <p><i>The SCIP no. of the affected products, please contact vertrieb@hydrotechnik.com.</i></p> <p><i>You can use this for your simplified SCIP notification (SSN) with ECHA.</i></p>
-------------------------------------	---	--

<p>Empfehlung zur Lagerung Suggestion for storage</p>	<p>Lagerzeiten werden in Anlehnung an DIN 7716 je nach Elastomer Typ unterschieden.</p>		<p><i>The storage time is in according to DIN 7716 different between the sealing types.</i></p>	
	<p>NBR</p>	<p>4 Jahre</p>	<p>NBR</p>	<p>4 years</p>
	<p>EPDM</p>	<p>6 Jahre</p>	<p>EPDM</p>	<p>6 years</p>
	<p>FKM</p>	<p>8 Jahre</p>	<p>FKM</p>	<p>8 years</p>

<p>Verpackung Packaging</p>	<p>VPE in Karton-Box oder in PE-Beutel und Umverpackung. Alternativen nach Absprache.</p>	<p><i>Packing unit in cardboard box or in PE-bag and overpack. Alternative packaging on request.</i></p>
---	---	--

<p>Sicherheitshinweise Safety indication</p>	<p>Die Montage des Produktes darf nur von Fachpersonal durchgeführt werden.</p>	<p>The installation should be carried out by qualified personnel</p>
--	---	--

Programm MINIMESS® Reihe 1620
Program MINIMESS® series 1620

MINIMESS® Testpunkt	
<i>MINIMESS® test point</i>	6
MINIMESS® Testpunkt mit DKO-Stützen	
<i>MINIMESS® test point with DKO fitting</i>	12
MINIMESS® Testpunkt mit T-Verschraubung	
<i>MINIMESS® test point with tee adaptor</i>	15
MINIMESS® Testpunkt mit DKO-Kombiverschraubung	
<i>MINIMESS® test point with DKO male / female tee adaptors</i>	17
MINIMESS® Testpunkt in Schottausführung	
<i>MINIMESS® test point with bulkhead adaptor</i>	19
MINIMESS® Testpunkt mit 37° - Bördelverschraubung	
<i>MINIMESS® test point with 37°- flared fitting adaptor</i>	20
MINIMESS® Manometer Anschluss für Schottwand	
<i>MINIMESS® pressure gauge connection for bulkhead fitting</i>	21
MINIMESS® Direktanschluss	
<i>MINIMESS® pressure gauge direct connection</i>	22
MINIMESS® Direktanschluss 90°	
<i>MINIMESS® pressure gauge direct connection 90°</i>	23
MINIMESS® 90° Schwenkverschraubung	
<i>MINIMESS® 90° swivel screw connection</i>	24
MINIMESS® Testpunkt mit ORFS Verschraubung	
<i>MINIMESS® test point with ORFS screw connection</i>	25
MINIMESS® Testpunkt mit Messstutzen	
<i>MINIMESS® test point with gauge port</i>	26

Weitere Ausführungen, Werkstoffe, Dichtungen und Einschraubgewinde auf Anfrage.
Other designs, materials, seals and screw-in thread on request.

MINIMESS® Testpunkt
MINIMESS® test point

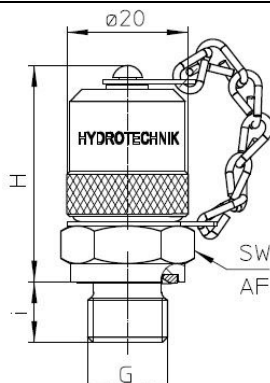
	Testpunkt nach ISO 15171-2 Test point according to ISO 15171-2						
	Hydrotechnik Form Hydrotechnik type	Normenbezug Normative reference	Anzugsmoment ¹ M [Nm] Locking torque ¹ M [Nm]	p_n^2 [bar]	H^3 [mm]	i [mm]	SW AF
Gewinde G screw thread G							
M12 x 1.5	B	ISO 9974-3	45	630	36	10	17
M14 x 1.5			60	630	36	10	19
M10 x 1	E	ISO 6149-2	20	630	37.5	9.5	17
M12 x 1.5			35	630	35.1	11	17
M14 x 1.5			45	630	35.5	11	19
M10 x 1	F	ISO 9974-2	20	400	37.6	8	17
M12 x 1.5			45	630	36	10	17
M14 x 1.5			60	630	36	10	19
M16 x 1.5			80	630	36	10	22
M8 x 1	G	-	6	250	41	8.5	17
M10 x 1			15	630	37.5	8.5	17
ISO 228-G 1/4	B	ISO 1179-4	60	630	36	10	19
ISO 228-G 1/8	F	ISO 1179-2	20	400	38	8	17
ISO 228-G 1/4			60	630	36	10	19
ISO 228-G 3/8			90	630	36	10	22
7/16-20 UNF	E	ISO 11926-2	20	630	37	11	17
9/16-18 UNF			35	630	36	12	17
ISO 7/I-R 1/8	C	DIN 3852-2 Form C	-	400	33	13	17
ISO 7/I-R 1/4			-	630	33	13	17
1/8 NPTF	H	Form H ANSI/ASME B1.20.2	-	400	33	9.5	17
1/4 NPTF			-	630	33	16.5	17

¹ Anzugsdrehmoment für Einschraubzapfen nach den zugehörigen Normen. Es obliegt dem Anwender für seine Einbausituation das passende Montagedrehmoment zu bestimmen.

Locking torque for stud ends according to the associated standards. It is the responsibility of the user to determine the assembly torque for his installation situation.

² p_n = maximaler Betriebsdruck / maximum working pressure

³ Testpunkte mit Kunststoffkappe H +3 mm / test points with plastic cap H +3 mm

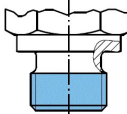
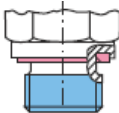
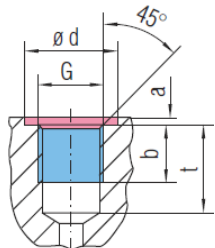
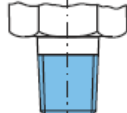
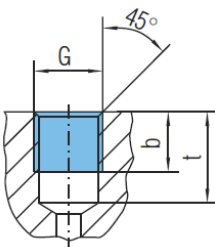
Einschraubzapfen Formen und empfohlene Einschraublöcher Screw-in plug types and recommend thread ports					
Einschraubzapfen Screw-in plug	Einschraubloch für Ölanwendungen Thread port for hydraulic applications				
Hydrotechnik Form B ISO 9974-3, ISO 1179-4  Abdichtung mit Dichtkante <i>Sealed with dealing edge</i>	G	d	a	b	t
	M10 x 1	15.0	1.0	8	13.0
	M12 x 1.5	18.0	1.5	12.0	18.5
	M 14 x 1.5	20.0	1.5	12.0	18.5
	M 16 x 1.5	22.0	1.5	12.0	18.5
	ISO 228-G 1/8	15.0	1.0	8.0	13.0
	ISO 228-G 1/4	20.0	1.5	12.0	18.5
ISO 228-G 3/8	23.0	2.0	12.0	18.5	
Hydrotechnik Form F ISO 9974-2, ISO 1179-2  Abdichtung mit Profildichtring <i>Sealed with profile gasket</i>	 ISO 9974-1, ISO 1179-1				
Hydrotechnik Form C DIN 3852-2 Form C  Abdichtung durch geeignetes Dichtmittel <i>Sealed with suitable sealant</i>	G	b	t	 DIN3852-2 Form Z	
	ISO7/1 – R1/8	5.5	9.5		
ISO7/1 – R1/4	8.5	13.5			

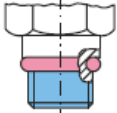
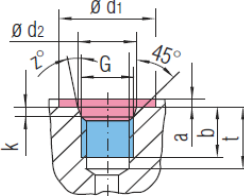
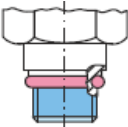
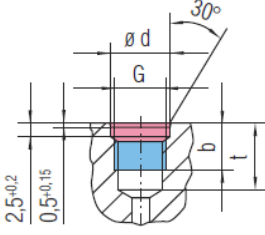
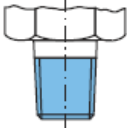
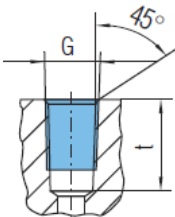
Einschraubzapfen Screw-in plug	Einschraubloch für Ölanwendungen Thread port for hydraulic applications							
<p>Hydrotechnik Form E ISO 6149-2, ISO 11926-2, SAE J514</p>  <p>Abdichtung mit O-Ring Sealed with O-ring</p>	G	d₁	d₂	b	k	t	a	z
	M10 x 1	19.0	11.1	10.0	1.6	11.5	1.0	12.0
	M12 x 1.5	19.0	13.8	11.5	2.4	14.0	1.5	15.0
	M14 x 1.5	21.0	15.8	11.5	2.4	14.0	1.5	15.0
	7/16-20 UNF	21.0	12.4	11.5	2.4	14.0	1.6	12.0
	9/16-18 UNF	25.0	15.6	12.7	2.5	15.5	1.6	12.0
 <p style="text-align: center;">ISO 6149-1, ISO 11926-1, SAE J1926-1</p>								
<p>Hydrotechnik Form G¹</p>  <p>Abdichtung mit O-Ring Sealed with O-ring</p>	G	d		b		t		
	M8 x 1	9.5		9.0		13.0		
	M10 x 1	11.5		9.0		13.0		
 <p style="text-align: center;">Hydrotechnik Standard¹</p>								
<p>Hydrotechnik Form H ANSI / ASME B1.20.2 Form H</p>  <p>Selbstdichtendes Gewinde Self-sealing thread</p>	G				t			
	1/8 NPTF				12.0			
	1/4 NPTF				17.5			
 <p style="text-align: center;">ANSI / ASME B1.20.2 Form H</p>								

¹ Einschraubzapfen Form G entsprechend Hydrotechnik Werknorm / Screw-in plug form G according to Hydrotechnik standard

Bestellnummern / Order numbers

Automatenstahl 1.0718 / free cutting steel 1.0718					
Gewinde G <i>thread G</i>	Abdichtart <i>sealing type</i>	Dichtung <i>sealing</i>	Kappenart <i>cap type</i>	Bestellnummer <i>Ordering number</i>	
M12 x 1.5	B	NBR	Metall / <i>metal</i>	2103-01-48.00N	
M14 x 1.5		NBR	Kunststoff / <i>plastic</i>	2103-30-49.00N	
		FKM	Kunststoff / <i>plastic</i>	2103-30-49.10N	
M10 x 1	E	NBR	Metall / <i>metal</i>	2103-01-94.00N	
M12 x 1.5		NBR	Metall / <i>metal</i>	2103-01-95.00N	
		FKM	Kunststoff / <i>plastic</i>	2103-30-95.10N	
M14 x 1.5		NBR	Metall / <i>metal</i>	2103-01-96.00N	
		NBR	Kunststoff / <i>plastic</i>	2103-30-96.00N	
M10 x 1	F	NBR	Metall / <i>metal</i>	2103-01-12.00N	
		FKM	Metall / <i>metal</i>	2103-01-12.10N	
M12 x 1.5		NBR	Metall / <i>metal</i>	2103-01-13.00N	
		FKM	Metall / <i>metal</i>	2103-01-13.10N	
M14 x 1.5		NBR	Kunststoff / <i>plastic</i>	2103-30-13.00N	
		FKM	Kunststoff / <i>plastic</i>	2103-30-13.10N	
		NBR	Metall / <i>metal</i>	2103-01-14.00N	
		FKM	Metall / <i>metal</i>	2103-01-14.10N	
M16 x 1.5		NBR	Kunststoff / <i>plastic</i>	2103-30-14.00N	
		FKM	Kunststoff / <i>plastic</i>	2103-30-14.10N	
M8 x 1		G	NBR	Metall / <i>metal</i>	2103-01-15.00N
			FKM	Metall / <i>metal</i>	2103-01-15.10N
M10 x 1	NBR		Metall / <i>metal</i>	2103-01-32.00N ¹	
		NBR	Metall / <i>metal</i>	2103-01-33.00N ¹	
		FKM	Metall / <i>metal</i>	2103-01-33.10N ¹	
ISO 228-G 1/4	B	NBR	Metall / <i>metal</i>	2103-01-51.00N	
		NBR	Kunststoff / <i>plastic</i>	2103-30-51.00N	
		FKM	Kunststoff / <i>plastic</i>	2103-30-51.10N	

¹ Einschraubzapfen Form G entsprechend Hydrotechnik Werknorm / *Screw-in plug form G according to Hydrotechnik standard*

Automatenstahl 1.0718 / free cutting steel 1.0718					
Gewinde G thread G	Abdichtart sealing type	Dichtung sealing	Kappenart cap type	Bestellnummer Ordering number	
ISO 228-G 1/8	F	NBR	Metall / metal	2103-01-17.00N	
		FKM	Metall / metal	2103-01-17.10N	
		NBR	Kunststoff / plastic	2103-30-17.00N	
		FKM	Kunststoff / plastic	2103-30-17.10N	
ISO 228-G 1/4		NBR	Metall / metal	2103-01-18.00N	
		FKM	Metall / metal	2103-01-18.10N	
		NBR	ohne Kappe / w/o cap	2103-02-18.00N	
		NBR	Kunststoff / plastic	2103-30-18.00N	
ISO 228-G 1/4	F	FKM	Kunststoff / plastic	2103-30-18.10N	
		NBR	Metall / metal	2103-01-18.00F1N ¹	
		NBR	Metall / metal	2103-01-18.00F2N ²	
		NBR	Metall / metal	2103-01-18.00F3N ³	
ISO 228-G 3/8		NBR	Metall / metal	2103-01-16.00N	
		FKM	Metall / metal	2103-01-16.10N	
7/16-20 UNF		E	NBR	Metall / metal	2103-01-B5.00N
			FKM	Metall / metal	2103-01-B5.10N
9/16-18 UNF	NBR		Metall / metal	2103-01-B6.00N	
	FKM		Metall / metal	2103-01-B6.10N	
	FKM		Kunststoff / plastic	2103-30-B6.10N	
ISO 7/I-R 1/8	C	NBR	Metall / metal	2103-01-40.00N	
ISO 7/I-R 1/4		NBR	Metall / metal	2103-01-41.00N	
1/8 NPTF	H	NBR	Metall / metal	2103-01-46.00N	
		FKM	Metall / metal	2103-01-46.10N	
1/4 NPTF		NBR	Metall / metal	2103-01-47.00N	
		FKM	Metall / metal	2103-01-47.10N	
		NBR	ohne Kappe / w/o cap	2103-02-47.00N	

Betriebstemperaturbereich / operating temperature range:

mit NBR-Dichtung / with NBR sealing: -25°C...+100°C / -13°F...+212°F

mit FKM-Dichtung / with FKM sealing: -20°C...+200°C (bei Kunststoffkappe bis +100°C) / -4°F...+392°F (with plastic cap to + 100°C)

¹ mit 0,22 mm Blende und Sieb im Einschraubzapfen / with 0.22 mm orifice and sieve in the screw-in plug

² mit 0,30 mm Blende und Sieb im Einschraubzapfen / with 0.30 mm orifice and sieve in the screw-in plug

³ mit 0,18 mm Blende und Sieb im Einschraubzapfen / with 0.18 mm orifice and sieve in the screw-in plug

Edelstahl 1.4571 / stainless steel 1.4571				
Gewinde G <i>thread G</i>	Abdichtart <i>sealing type</i>	Dichtung <i>sealing</i>	Kappenart <i>cap type</i>	Bestellnummer <i>Ordering number</i>
ISO 228-G 1/8	F	FKM	Metall / <i>metal</i>	2703-01-17.10
ISO 228-G 1/4		FKM	Metall / <i>metal</i>	2703-01-18.10
		NBR	Metall / <i>metal</i>	2703-01-18.56 ¹
7/16-20 UNF	E	NBR	Metall / <i>metal</i>	2703-01-21.10
1/4 NPTF	H	FKM	Metall / <i>metal</i>	2703-01-47.10

Betriebstemperaturbereich / *operating temperature range:*

mit NBR-Dichtung / *with NBR sealing:* -25°C...+100°C / -13°F...+212°F

mit FKM-Dichtung / *with FKM sealing:* -20°C...+200°C (bei Kunststoffkappe bis +100°C) / -4°F...+392°F (*with plastic cap to + 100°C*)

¹ Tieftemperatur NBR -50°C...+100°C / *low temperature NBR -58°F...+212°F*

MINIMESS® Testpunkt mit DKO-Stutzen
MINIMESS® test point with DKO fitting

Für lötlöse Rohrverschraubung nach DIN 2353
For solder free screw-in pipe connections according to DIN 2353

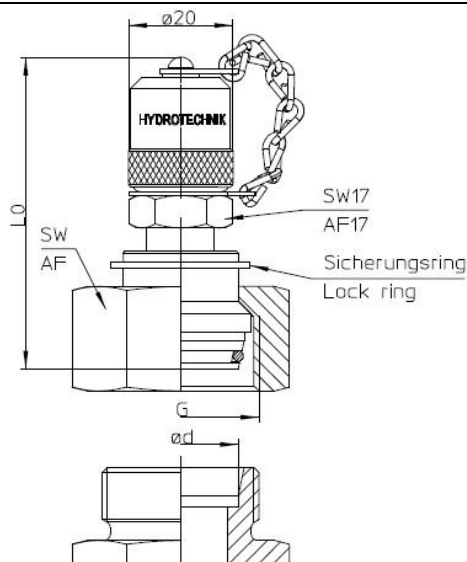
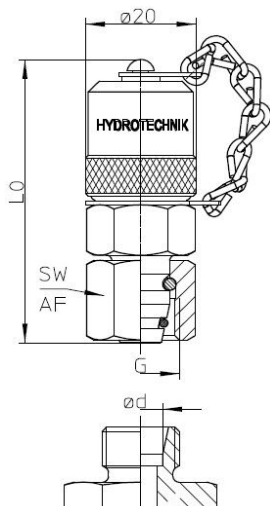

Reihe Ø d series Ø d	p _n ¹ [bar]	Gewinde G thread G	L ₀ ²	SW AF	Reihe Ø d series Ø d	p _n ¹ [bar]	Gewinde G thread G	L ₀ ²	SW AF
L 6	315	M12 x 1.5	52	14	L 22	160	M30 x 2	60	36
L 8		M14 x 1.5	52	17	L 28		M36 x 2	61	41
L 10		M16 x 1.5	52	19	L 35		M45 x 2	63	50
L 12		M18 x 1.5	52	22	L 42		M52 x 2	63	60
L 15		M22 x 1.5	52	27					
L 18		M26 x 1.5	52	32					
S 6	630	M14 x 1.5	52	17	S 20	400	M 30 x 2	63	36
S 8		M16 x 1.5	52	19	S 25		M 36 x 2	64.5	46
S 10		M18 x 1.5	52	22	S 30		M 42 x 2	66	50
S 12		M20 x 1.5	52	24	S 38	315	M 52 x 2	69	60
S 16	400	M24 x 1.5	52	30					

¹ p_n = maximaler Betriebsdruck / maximum working pressure

² Testpunkte mit Kunststoffkappe H +3 mm / test points with plastic cap H +3 mm

Bestellnummern / Order numbers

Automatenstahl 1.0718 / free cutting steel 1.0718

Reihe Ø d series Ø d	Gewinde G thread G	Dichtung sealing	Kappenart cap type	Bestellnummer Ordering number
L 6	M12 x 1.5	NBR	Metall / metal	2103-93-06.00N
		FKM	Metall / metal	2103-93-06.10N
L 8	M14 x 1.5	NBR	Metall / metal	2103-93-08.00N
		FKM	Metall / metal	2103-93-08.10N
		NBR	Kunststoff / plastic	2103-93-08.90N
		FKM	Kunststoff / plastic	2103-93-08.95N
L 10	M16 x 1.5	NBR	Metall / metal	2103-93-10.00N
		FKM	Metall / metal	2103-93-10.10N
		NBR	Kunststoff / plastic	2103-93-10.90N
		FKM	Kunststoff / plastic	2103-93-10.95N
L 12	M18 x 1.5	NBR	Metall / metal	2103-93-12.00N
		FKM	Metall / metal	2103-93-12.10N
		NBR	Kunststoff / plastic	2103-93-12.90N
		FKM	Kunststoff / plastic	2103-93-12.95N
L 15	M22 x 1.5	NBR	Metall / metal	2103-93-15.00N
		FKM	Metall / metal	2103-93-15.10N
		NBR	Kunststoff / plastic	2103-93-15.90N
		FKM	Kunststoff / plastic	2103-93-15.95N
L 18	M26 x 1.5	NBR	Metall / metal	2103-93-18.00N
		FKM	Kunststoff / plastic	2103-93-18.95N
L 22	M30 x 2	NBR	Metall / metal	2103-40-22.00N
L 28	M36 x 2	NBR	Metall / metal	2103-40-28.00N
L 35	M45 x 2	NBR	Metall / metal	2103-40-35.00N
L 42	M52 x 2	NBR	Metall / metal	2103-40-42.00N
S 6	M14 x 1.5	NBR	Metall / metal	2103-94-06.00N
S 8	M16 x 1.5	NBR	Metall / metal	2103-94-08.00N
		FKM	Metall / metal	2103-94-08.10N
		NBR	Kunststoff / plastic	2103-94-08.90N
		FKM	Kunststoff / plastic	2103-94-08.95N
S 10	M18 x 1.5	NBR	Metall / metal	2103-94-10.00N
		FKM	Metall / metal	2103-94-10.10N
S 12	M20 x 1.5	NBR	Metall / metal	2103-94-12.00N
		FKM	Metall / metal	2103-94-12.10N

Automatenstahl 1.0718 / free cutting steel 1.0718				
Reihe Ø d <i>series Ø d</i>	Gewinde G <i>thread G</i>	Dichtung <i>sealing</i>	Kappenart <i>cap type</i>	Bestellnummer <i>Ordering number</i>
S 16	M24 x 1.5	NBR	Metall / <i>metal</i>	2103-94-16.00N
		FKM	Metall / <i>metal</i>	2103-94-16.10N
S 20	M30 x 2	NBR	Metall / <i>metal</i>	2103-41-20.00N
		FKM	Kunststoff / <i>plastic</i>	2103-41-20.95N
S 25	M36 x 2	NBR	Metall / <i>metal</i>	2103-41-25.00N
		NBR	Kunststoff / <i>plastic</i>	2103-41-25.90N
S 30	M42 x 2	NBR	Metall / <i>metal</i>	2103-41-30.00N
S 38	M52 x 2	NBR	Metall / <i>metal</i>	2103-41-38.00N

Edelstahl 1.4571 / stainless steel 1.4571				
Reihe Ø d <i>series Ø d</i>	Gewinde G <i>thread G</i>	Dichtung <i>sealing</i>	Kappenart <i>cap type</i>	Bestellnummer <i>Ordering number</i>
L 6	M12 x 1.5	FKM	Metall / <i>metal</i>	2703-40-06.10
S 10	M18 x 1.5	FKM	Metall / <i>metal</i>	2703-41-10.10
S 12	M20 x 1.5	FKM	Metall / <i>metal</i>	2703-41-12.10

Betriebstemperaturbereich / *operating temperature range:*

mit NBR-Dichtung / *with NBR sealing:* -25°C...+100°C / -13°F...+212°F

mit FKM-Dichtung / *with FKM sealing:* -20°C...+200°C (bei Kunststoffkappe bis +100°C) / -4°F...+392°F (*with plastic cap to + 100°C*)

MINIMESS® Testpunkt mit T-Verschraubung
MINIMESS® test point with tee adaptor

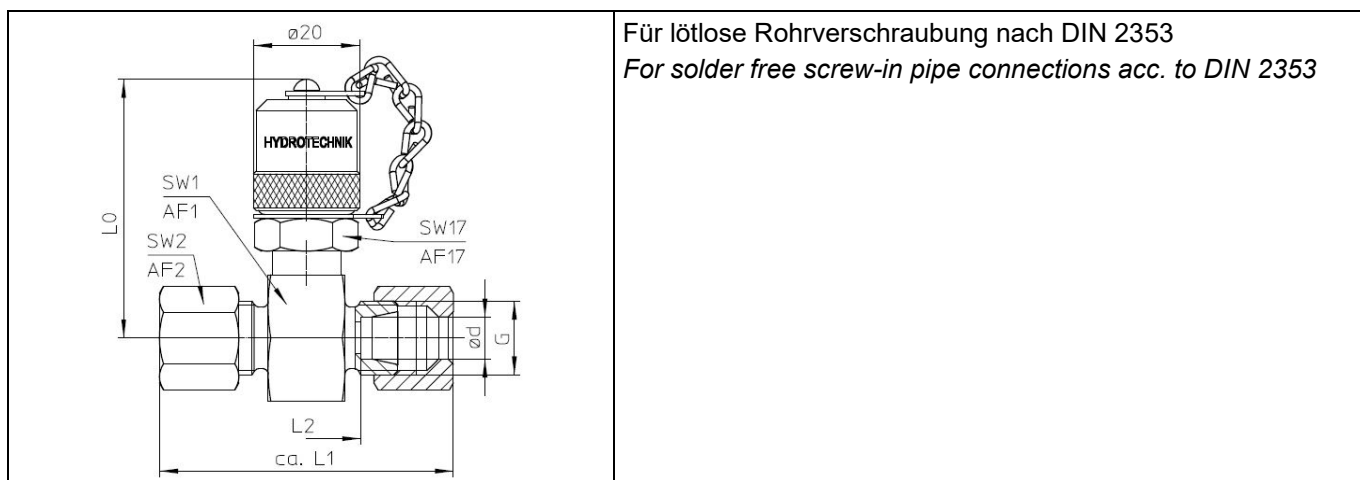

Für lötlöse Rohrverschraubung nach DIN 2353
For solder free screw-in pipe connections acc. to DIN 2353

Reihe Ø d series Ø d	pn ¹ [bar]	Gewinde G thread G	L ₀	L ₁	L ₂	SW ₁ AF ₁	SW ₂ AF ₂
L 6	315	M12 x 1.5	49.5	50.5	20.5	24	14
L 8		M14 x 1.5	49.5	50.5	20.5	24	17
L 10		M16 x 1.5	49.5	52.5	22.5	24	19
L 12		M18 x 1.5	49.5	52.5	22.5	24	22
L 15		M22 x 1.5	52.5	54.5	24.5	30	27
L 18		M26 x 1.5	53.5	56.5	23.5	32	32
L 22	160	M30 x 2	55.5	60.5	27.5	36	36
L 28		M36 x 2	58	60.5	27.5	41	41
S 6	630	M14 x 1.5	49.5	54.5	24.5	24	17
S 8		M16 x 1.5	49.5	54.5	24.5	24	19
S 10		M18 x 1.5	49.5	56.5	23.5	24	22
S 12		M20 x 1.5	49.5	56.5	23.5	24	24
S 16	400	M24 x 1.5	52.5	62.5	25.5	30	30
S 20		M30 x 2	55.5	68.5	25.5	36	36
S 25		M36 x 2	58	74.5	26.5	41	46
S 30		M42 x 2	60.5	80.5	27.5	46	50

¹ p_n = maximaler Betriebsdruck / maximum working pressure

Bestellnummern / Order numbers

Automatenstahl 1.0718 / free cutting steel 1.0718

Ausführung version	Reihe Ø d series Ø d	Gewinde G thread G	Dichtung sealing	Kappenart cap type	Bestellnummer Ordering number	
Mit Schneidring und Überwurfmutter <i>with cutting ring and union nut</i>	L 6	M12 x 1.5	NBR	Metall / metal	2103-11-06.00N	
	L 8	M14 x 1.5			2103-11-08.00N	
	L 10	M16 x 1.5			2103-11-10.00N	
	L 12	M18 x 1.5			2103-11-12.00N	
	L 15	M22 x 1.5			2103-11-15.00N	
	L 18	M26 x 1.5			2103-11-18.00N	
	L 22	M30 x 2			2103-11-22.00N	
	L 28	M36 x 2			2103-11-28.00N	
	S 6	M14 x 1.5	NBR	Metall / metal	2103-12-06.00N	
		S 8			M16 x 1.5	2103-12-08.00N
		S 10			M18 x 1.5	2103-12-10.00N
		S 12			M20 x 1.5	2103-12-12.00N
		S 16			M24 x 1.5	2103-12-16.00N
		S 20			M30 x 2	2103-12-20.00N
		S 25			M36 x 2	2103-12-25.00N
		S 30			M42 x 2	2103-12-30.00N
Ohne Schneidring und Überwurfmutter <i>without cutting ring and union nut</i>	L 6	M12 x 1.5	NBR	Metall / metal	2103-11-06.05N	
	L 8	M14 x 1.5			2103-11-08.05N	
	L 10	M16 x 1.5			2103-11-10.05N	
	L 12	M18 x 1.5			2103-11-12.05N	
	L 15	M22 x 1.5			2103-11-15.05N	
	L 18	M26 x 1.5			2103-11-18.05N	
	L 22	M30 x 2			2103-11-22.05N	
	L 28	M36 x 2			2103-11-28.05N	
	S 6	M14 x 1.5	NBR	Metall / metal	2103-12-06.05N	
		S 8			M16 x 1.5	2103-12-08.05N
		S 10			M18 x 1.5	2103-12-10.05N
		S 12			M20 x 1.5	2103-12-12.05N
		S 16			M24 x 1.5	2103-12-16.05N
		S 20			M30 x 2	2103-12-20.05N
		S 25			M36 x 2	2103-12-25.05N
		S 30			M42 x 2	2103-12-30.05N

Betriebstemperaturbereich: -25°C...+100°C / Operating temperature range: -13°F...+212°F

MINIMESS® Testpunkt mit DKO-Kombiverschraubung
MINIMESS® test point with DKO male / female tee adaptors

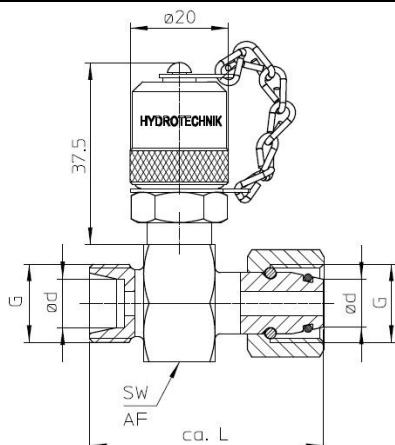

Für lötlöse Rohrverschraubung nach DIN 2353
For solder free screw-in pipe connections according to DIN 2353

Reihe $\varnothing d$ series $\varnothing d$	p_n^1 [bar]	Gewinde G thread G	d	L	SW AF	
L 6	315	M12 x 1.5	6	44.5	24	
L 8		M14 x 1.5	8	44.5	24	
L 10		M16 x 1.5	10	47.5	24	
L 12		M18 x 1.5	12	48.5	24	
L 15		M22 x 1.5	15	51.5	30	
L 18		M26 x 1.5	18	55.5	32	
L 22	160	M30 x 2	22	58.5	36	
S 8	630	M16 x 1.5	8	48.5	24	
S 10		M18 x 1.5	10	49.5	24	
S 12		M20 x 1.5	12	50	24	
S 16	400	M24 x 1.5	16	56.5	30	
S 20		M30 x 2	20	64.5	36	
S 25		M36 x 2	25	66	41	

¹ p_n = maximaler Betriebsdruck / maximum working pressure

Bestellnummern / Order numbers

Automatenstahl 1.0718 / free cutting steel 1.0718

Reihe Ø d series Ø d	Gewinde G ¹ thread G ¹	Dichtung sealing	Kappenart cap type	Bestellnummer Ordering number
L 6	M12 x 1.5	NBR	Metall / metal	2103-KL-06.00N
L 8	M14 x 1.5			2103-KL-08.00N
L 10	M16 x 1.5			2103-KL-10.00N
L 12	M18 x 1.5			2103-KL-12.00N
L 15	M22 x 1.5			2103-KL-15.00N
L 18	M26 x 1.5			2103-KL-18.00N
L 22	M30 x 2			2103-KL-22.00N
S 8	M16 x 1.5	NBR	Metall / metal	2103-KS-08.00N
S 10	M18 x 1.5			2103-KS-10.00N
S 12	M20 x 1.5			2103-KS-12.00N
S 16	M24 x 1.5			2103-KS-16.00N
S 20	M30 x 2			2103-KS-20.00N
S 25	M36 x 2			2103-KS-25.00N

Betriebstemperaturbereich: -25°C...+100°C / Operating temperature range: -13°F...+212°F

¹ Einschraubzapfen Form G entsprechend Hydrotechnik Werknorm / Screw-in plug form G according to Hydrotechnik standard

MINIMESS® Testpunkt in Schottausführung
MINIMESS® test point with bulkhead adaptor

Für lötlöse Rohrverschraubung nach DIN 2353
For solder free screw-in pipe connections according to DIN 2353

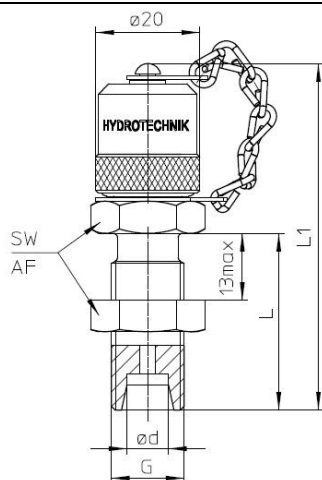

For MINIMESS® 1620 Anschluss
For MINIMESS® 1620 connection

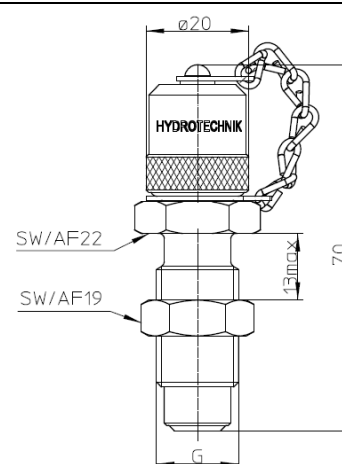

Reihe Ø d series Ø d	p _n ¹ [bar]	Gewinde G thread G	L	L ₁	SW AF	Anschluss connection	p _n ¹ [bar]	Gewinde G thread G
L 8	315	M14 x 1.5	34	67	19	MINIMESS® 1620 beidseitig on both sides	630	M16 x 2
S 6	630	M14 x 1.5	36	69	19			
S 8		M16 x 1.5	33.5	66.5	22			

¹ p_n = maximaler Betriebsdruck / maximum working pressure

Bestellnummern / Order numbers

Automatenstahl 1.0718 / free cutting steel 1.0718				
Reihe / Anschluss series / connection	Gewinde G thread G	Dichtung sealing	Kappenart cap type	Bestellnummer Ordering number
L 8	M14 x 1.5	NBR	Metall / metal	2103-04-23.00N
S 6	M14 x 1.5	NBR	Metall / metal	2103-04-24.00N
S 8	M16 x 1.5			2103-04-25.00N
MINIMESS® 1620 beidseitig on both sides	M16 x 2	NBR	Metall / metal	2103-04-16.00N

Betriebstemperaturbereich: -25°C...+100°C / Operating temperature range: -13°F...+212°F

MINIMESS® Testpunkt mit 37° - Bördelverschraubung
MINIMESS® test point with 37°- flared fitting adaptor

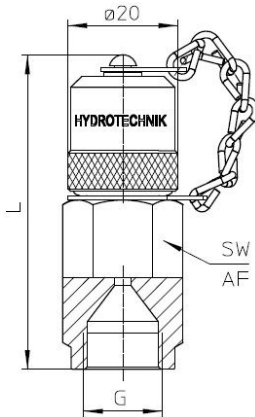
		<p>37° - Bördelverschraubung nach SAE J514 37°- flared fitting according to SAE J514</p>				
Gewinde G thread G	p _n ¹ [bar]	Rohr-Ø pipe-Ø [mm]	Rohr-Ø pipe-Ø [Zoll / inch]	L	SW AF	
7/16-20 UNF	600	6	1/4	55	17	
9/16 -18 UNF	315	10	3/8	57.5	19	

¹p_n = maximaler Betriebsdruck / maximum working pressure

Bestellnummern / Order numbers

Automatenstahl 1.0718 / free cutting steel 1.0718					
Gewinde G thread G	Rohr-Ø pipe-Ø [mm]	Rohr-Ø pipe-Ø [Zoll / inch]	Dichtung sealing	Kappenart cap type	Bestellnummer Ordering number
7/16-20 UNF	6	1/4	NBR	Metall / metal	2103-85-21.00N
9/16 -18 UNF	10	3/8	NBR	Metall / metal	2103-85-23.00N

Betriebstemperaturbereich: -25°C...+100°C / Operating temperature range: -13°F...+212°F

MINIMESS® Manometer Anschluss für Schottwand
MINIMESS® pressure gauge connection for bulkhead fitting

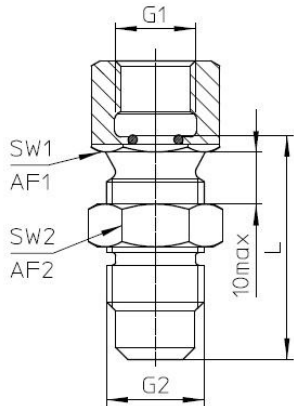
						
Innengewinde G1 <i>internal thread G1</i>	p_n^1 [bar]	Anschluss G2 <i>connection G2</i>	L [mm]	SW 1 AF 1	SW 2 AF 2	
ISO 228 G1/4	630	1620 / M16 x 2	38	19	19	
ISO 228 G1/2			42.5	27	19	
1/4 NPT			-	19	19	

¹ p_n = maximaler Betriebsdruck / *maximum working pressure*

Bestellnummern / Order numbers

Automatenstahl 1.0718 / free cutting steel 1.0718

Innengewinde G1 <i>internal thread G1</i>	Anschluss G2 <i>connection G2</i>	Anmerkung <i>remark</i>	Dichtung <i>sealing</i>	Bestellnummer <i>Ordering number</i>
ISO 228 G1/4	1620 / M16 x 2	Ohne Rückschlagventil <i>without return valve</i>	NBR	2103-05-11.00N
ISO 228 G1/2			FKM	2103-05-11.10N
			NBR	2103-05-12.00N
1/4 NPT			FKM	2103-05-12.10N
			NBR	2103-05-23.00N

Edelstahl 1.4571 / stainless steel 1.4571

Innengewinde G1 <i>internal thread G1</i>	Anschluss G2 <i>connection G2</i>	Anmerkung <i>remark</i>	Dichtung <i>sealing</i>	Bestellnummer <i>Ordering number</i>
ISO 228 G1/4	1620 / M16 x 2	Ohne Rückschlagventil <i>without return valve</i>	FKM	2703-05-11.10

Betriebstemperaturbereich / *operating temperature range:*

mit NBR-Dichtung / *with NBR sealing:* -25°C...+100°C / -13°F...+212°F

mit FKM-Dichtung / *with FKM sealing:* -20°C...+200°C / -4°F...+392°F

MINIMESS® Direktanschluss
MINIMESS® pressure gauge direct connection

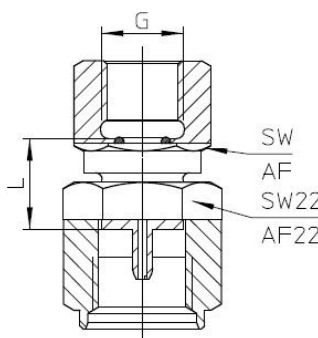
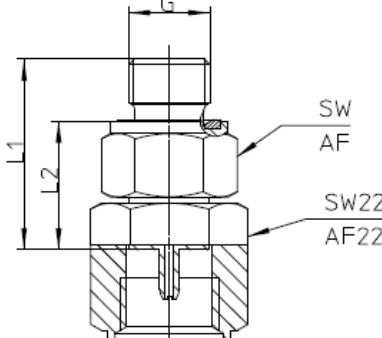
								
Innengewinde G <i>internal thread G</i>	p_n^1 [bar]	L [mm]	SW AF	Außengewinde G <i>external thread G</i>	p_n^1 [bar]	L ₁ [mm]	L ₂ [mm]	SW AF
ISO 228 G1/4	630	14.5	19	ISO 228 G1/4 Form F	630	30.7	20.7	19
ISO 228 G1/2		17	27					
1/4 NPT		-	19					

¹ p_n = maximaler Betriebsdruck / maximum working pressure

Bestellnummern / Order numbers

Automatenstahl 1.0718 / free cutting steel 1.0718

Innengewinde <i>internal thread</i>	Dichtung <i>sealing</i>	Bestellnummer <i>Ordering number</i>	Außengewinde <i>external thread</i>	Dichtung <i>sealing</i>	Bestellnummer <i>Ordering number</i>
ISO 228 G1/4	NBR	2103-07-11.62N	ISO 228 G1/4 Form F	NBR	2103-07-41.62N
	FKM	2103-07-11.63N			
	- ¹	2103-07-18.62N			
ISO 228 G1/2	NBR	2103-07-12.62N			
1/4 NPT	-	2103-07-23.62N			

¹ für Druckaufnehmer ohne Dichtring und Düse / for pressure sensor without seal ring and orifice

Edelstahl 1.4571 / stainless steel 1.4571

Innengewinde <i>internal thread</i>	Dichtung <i>sealing</i>	Bestellnummer <i>Ordering number</i>
ISO 228 G1/4	FKM	2703-07-11.62

Betriebstemperaturbereich / operating temperature range:

mit NBR-Dichtung / with NBR sealing: -25°C...+100°C / -13°F...+212°F

mit FKM-Dichtung / with FKM sealing: -20°C...+200°C / -4°F...+392°F

MINIMESS® Direktanschluss 90°
MINIMESS® pressure gauge direct connection 90°

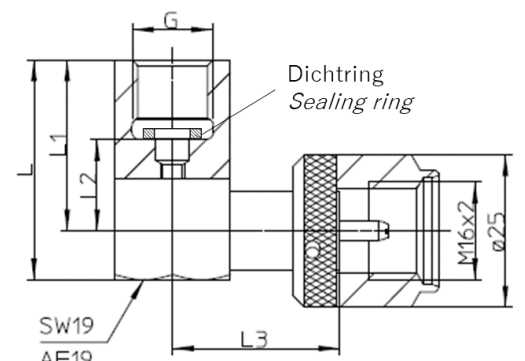
						
Innengewinde G <i>internal thread G</i>	p_n^1 [bar]	L [mm]	L ₁ [mm]	L ₂ [mm]	L ₃ [mm]	
ISO 228 G1/4	630	36	28	15	27.5	

Bestellnummern / Order numbers

Automatenstahl 1.0718 / free cutting steel 1.0718

Innengewinde G <i>internal thread G</i>	Dichtring <i>Sealing ring</i>	Bestellnummer <i>Ordering number</i>	
ISO 228 G1/4	Kupfer <i>copper</i>	2146-13-05.00N	

¹ p_n = maximaler Betriebsdruck / *maximum working pressure*

MINIMESS® 90° Schwenkverschraubung
MINIMESS® 90° swivel screw connection

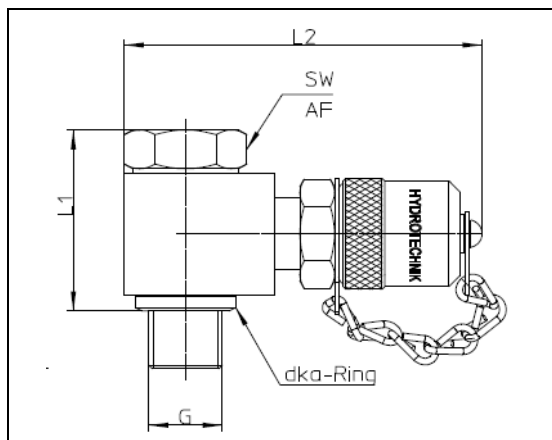

Abdichtung am Einschraubgewinde (Hohlschraube) über DKA-Ring, am Sechskant über Gi-Ring (NBR).
Sealing on screw-in thread (hollow screw) via DKA-ring, on hexagonal via Gi-ring (NBR).

Gewinde G thread G	p _n ¹ [bar]	L ₁ [mm]	L ₂ [mm]	SW 1 AF 1	SW 2 AF 2	
ISO 228 G1/4	630	34.5	64.5	19	19	

Bestellnummern / Order numbers

Automatenstahl 1.0718 / free cutting steel 1.0718

Gewinde thread	Dichtung sealing	Kappenart cap type	Bestellnummer Ordering number	
ISO 228 G1/4	NBR	Metall / metal	2115-22-34.00N	
	FKM		2115-22-34.10N	

Betriebstemperaturbereich / operating temperature range:

mit NBR-Dichtung / with NBR sealing: -25°C...+100°C / -13°F...+212°F

mit FKM-Dichtung / with FKM sealing: -20°C...+200°C / -4°F...+392°F

¹ p_n = maximaler Betriebsdruck / maximum working pressure

MINIMESS® Testpunkt mit ORFS Verschraubung
MINIMESS® test point with ORFS screw connection

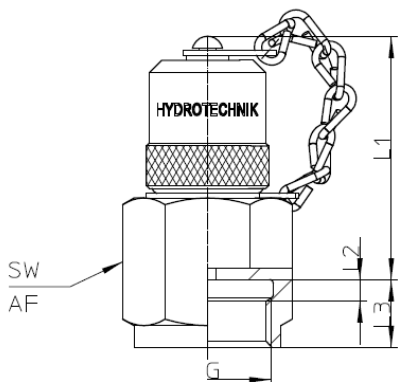
						
Gewinde G thread G	p _n ¹ [bar]	L ₁ [mm]	L ₂ [mm]	L ₃ [mm]	SW AF	
11/16-16 UNF	630	40	3.5	10	22	

Bestellnummern / Order numbers

Automatenstahl 1.0718 / free cutting steel 1.0718

Gewinde thread	Dichtung sealing	Kappenart cap type	Bestellnummer Ordering number	
11/16-16 UNF	NBR	Metall / metal	2103-56-12.00N	

Betriebstemperaturbereich: -25°C...+100°C / Operating temperature range: -13°F...+212°F

¹ p_n = maximaler Betriebsdruck / maximum working pressure

MINIMESS® Testpunkt mit Messstutzen
MINIMESS® test point with gauge port

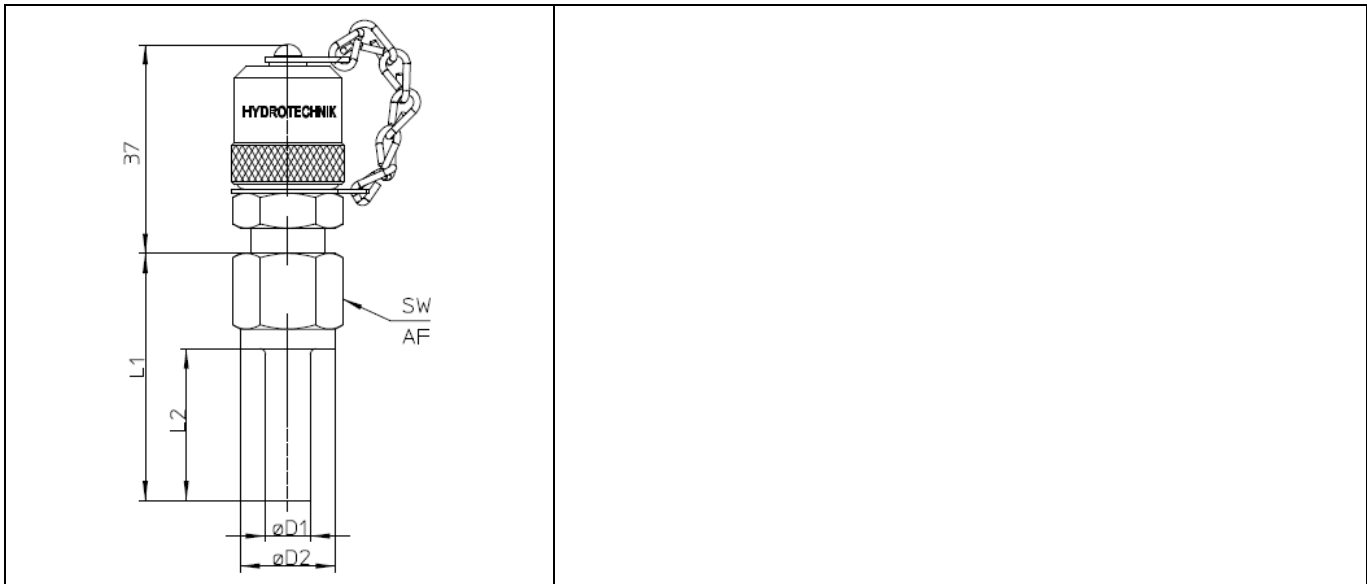

Reihe Ø D ₁ series Ø D ₁	p _n ¹ [bar]	D ₂ [mm]	L ₁ [mm]	L ₂ [mm]	SW AF
L/S 6	630	16.9	44	27	17
L/S 8			44	27	
L/S 10			45	29	
L/S 12			45	29	

Bestellnummern / Order numbers

Automatenstahl 1.0718 / free cutting steel 1.0718			
Reihe Ø D ₁ series Ø D ₁	Dichtung sealing	Kappenart cap type	Bestellnummer Ordering number
L/S 6	NBR	Metall / metal	2103-15-06.00N
L/S 8	NBR	Metall / metal	2103-15-08.00N
L/S 10	NBR	Metall / metal	2103-15-10.00N
L/S 12	NBR	Metall / metal	2103-15-12.00N

Betriebstemperaturbereich: -25°C...+100°C / Operating temperature range: -13°F...+212°F

Revision	Rev 00	Rev 01	Rev 02	Rev 03	Rev 04	Rev 05	Rev 06	Rev 07
	TW	MA	MA					
	2018-11-20	2023-05-23	2024-03-18					

¹ p_n = maximaler Betriebsdruck / maximum working pressure

